

Operation Key Information

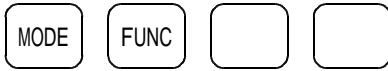



Model : TTM - 004 / TTM - X04
 Name : Temperature Controller
 Job No. : K144 / K146

承認 APPROVED	承認 APPROVED	照査 CHECKED	作成 DESIGNED	作成日 DATE '99.12.16	Job.No. K144/K146	名称 TITLE Operation key Information	
				機種 MODEL TTM - 004 / TTM - X04		図番 DWG.No.	PAGE
				東邦電子株式会社			1/21

	図番 DWG.	PAGE 2/21
--	---------	--------------

1 . Operation Key Information



Operation Key	Description
MODE Key 	• For change of display (Memorizing the set up parameters when pressing MODE Key)
Function Key 	• Following Practicable functions available for selection. 1) Change of digit All mode 2) AT key Operation mode only 3) Run/Ready key Operation mode only 4) Timer start/Reset Operation mode only
DOWN Key 	• For decrease of setting value (Over 1s and below 10s at continuous press : 1 digit/100ms) (Over 10s and below 20s at continuous press : 10 digits/100ms) (Over 20s at continuous press : 100 digits/100ms)
UP Key 	• For increase of setting value It is the same DOWN Key operation.

2 . Operation Flow

Power ON

After power ON, it shows " Type of Input display" for 4 seconds and goes on to "Operation Mode"

Initial display
(4 seconds)

Operation Mode

Press mode key over 2 seconds

Setting mode selection display

0	Mode Key	1	Mode Key	2	Mode Key	3	Mode Key	4	Mode Key	5	Mode Key	6	Mode Key	7	Mode Key
	Setting mode of priority display		Set-up setting mode		Control setting mode		EV1 setting mode		EV2 setting mode		DI setting mode		communi - cation setting mode		timer setting mode

" Each parameter mode setting mode selection display" : Press mode key over 2 seconds. If you remain each parameter display over 2 seconds, the display return to "operation mode"

	図番 DWG.	PAGE 3/21
--	---------	--------------

2.1 Operation Mode

PV

1200

 1.Setting of control
SV

0

Press mode key

PV

* * * *

 2.Priority display 1
SV

* * * *

Press mode key

PV

* * * *

 3.Priority display 2
SV

* * * *

Press mode key

PV

* * * *

 4.Priority display 3
SV

* * * *

Press mode key

PV

* * * *

 5.Priority display 4
SV

* * * *

Press mode key

PV

* * * *

 6.Priority display 5
SV

* * * *

Press mode key

PV

* * * *

 7.Priority display 6
SV

* * * *

Press mode key

PV

* * * *

 8.Priority display 7
SV

* * * *

Press mode key

PV

* * * *

 9.Priority display 8
SV

* * * *

Press mode key

PV

* * * *

 10.Priority display 9
SV

* * * *

Press mode key











Return to 1

2.2 Setting Mode of Priority Display

Notes : Underline is initial blind.

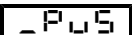
- PV SEt 1.Selection display for setting mode
SV 0
Press mode key
- PV Pr1 1 2.Setting function for priority display 1
SV oFF
Press mode key
- PV Pr1 2 3.Setting function for priority display 2
SV oFF
Press mode key
- PV Pr1 3 4.Setting function for priority display 3
SV oFF
Press mode key
- PV Pr1 4 5.Setting function for priority display 4
SV oFF
Press mode key
- PV Pr1 5 6.Setting function for priority display 5
SV oFF
Press mode key
- PV Pr1 6 7.Setting function for priority display 6
SV oFF
Press mode key
- PV Pr1 7 8.Setting function for priority display 7
SV oFF
Press mode key
- PV Pr1 8 9.Setting function for priority display 8
SV oFF
Press mode key
- PV Pr1 9 10.Setting function for priority display 9
SV oFF
Return to 1

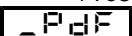
2.3 Set-Up Setting Mode

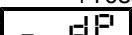
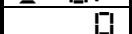
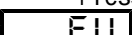
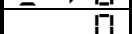
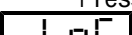
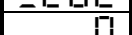
- PV  1.Selection display for setting mode
SV 
Press mode key
- PV  2.Setting of input types
SV 
Press mode key
- PV  3.Gain setting for PV correction
SV 
Press mode key
- PV  4.Zero point setting for PV correction
SV 
Press mode key
- PV  5.Setting of filter input
SV 
Press mode key
- PV  6.Setting of decimal position
SV 
Press mode key
- PV  7.Setting of function key
SV 
Press mode key
- PV  8.Setting of key-lock
SV 
Press mode key
Return to 1

	図番 DWG.	PAGE 6/21
--	---------	--------------

2.4 Control Setting Mode

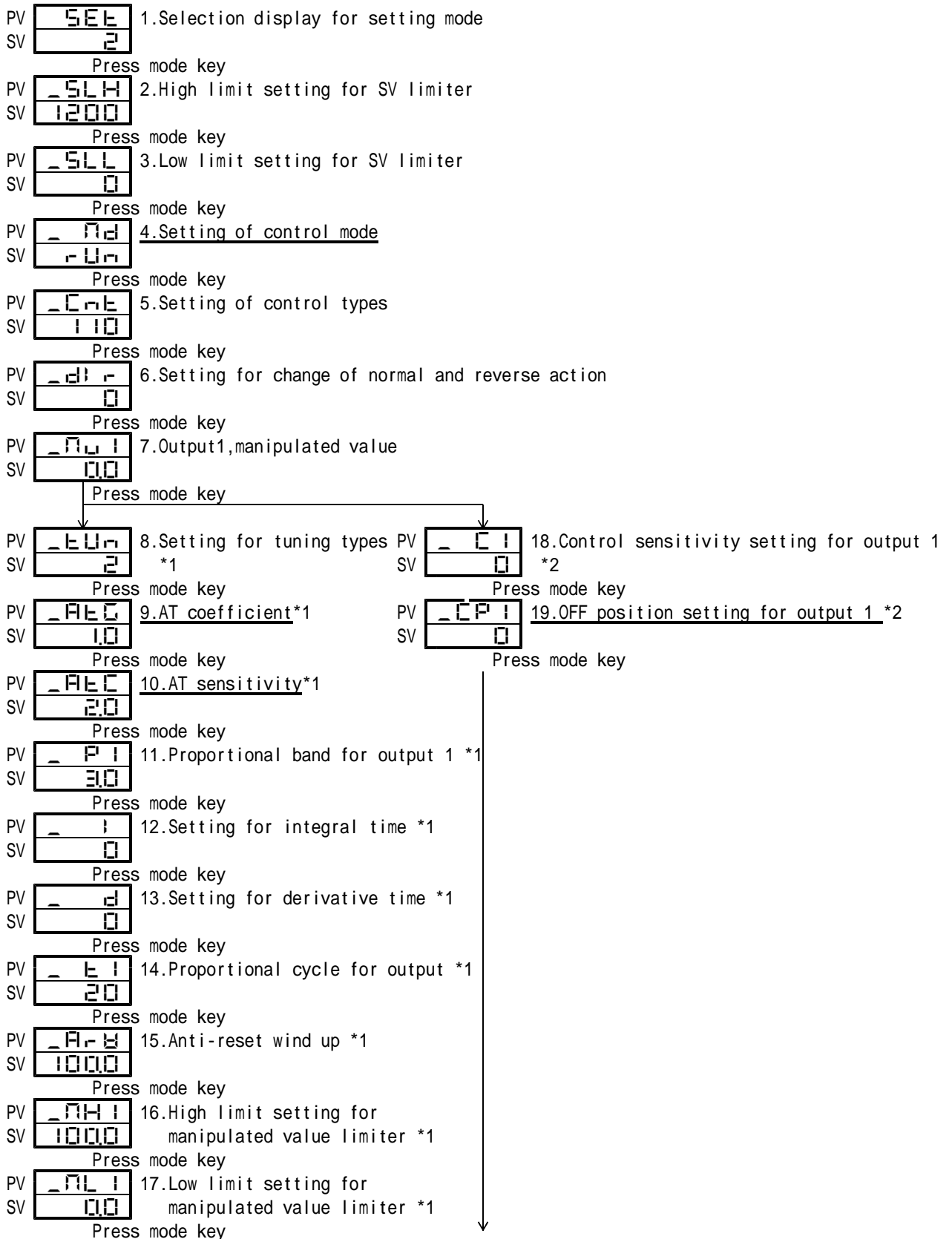



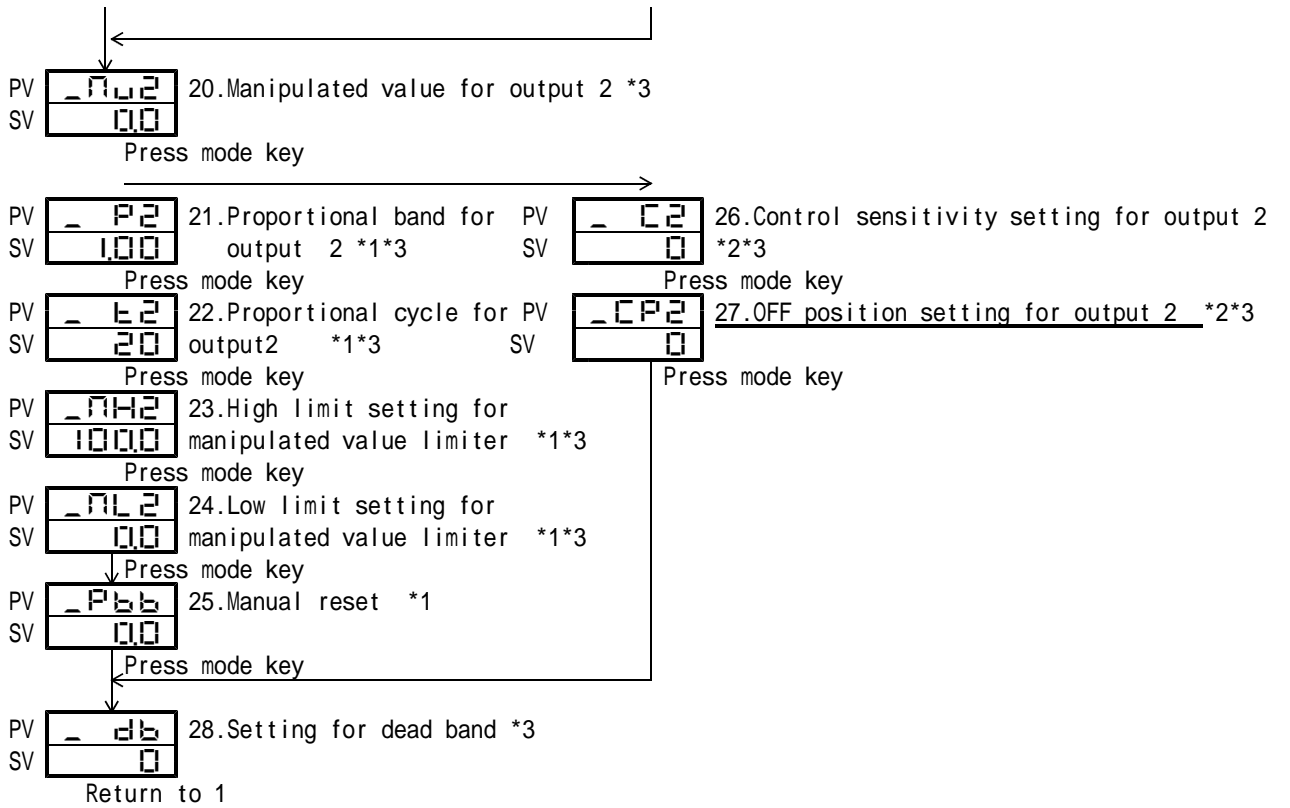

















	図番 DWG.	PAGE 7/21
--	---------	--------------

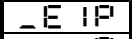

Notes

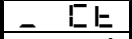
- *1 Not indicated for ON/OFF control.
- *2 Not indicated for PID control.
- *3 Not indicated unless output 2 is type-specified.

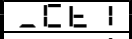



















2.5 Event Output 1 (EV Output 1) Parameter Mode

- PV  1.Selection display for setting mode
SV 
Press mode key
- PV  2.Setting for PV event output 1
SV 
Press mode key
- PV  3.High limit setting for EV output 1 *5*6
SV 
Press mode key
- PV  4.Low limit setting for EV output 1 *5*7
SV 
Press mode key
- PV  5.Sensitivity setting for EV output 1 *5
SV 
Press mode key
- PV  6.Delay timer setting for EV output 1 *8
SV 
Press mode key
- PV  7.Setting for abnormal PV/heater function in event output 1
SV 
Press mode key
- PV  8.Polarity setting for EV output 1
SV 
Press mode key
- PV  9.C T input Monitor *10
SV 
Press mode key
- PV  10.Abnormal current setting for EV output 1 *9
SV 
Press mode key
- Return to 1

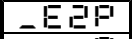
Notes

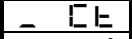
- *5 Not indicated unless EV output of measurement value (PV) is used.
- *6 Not indicated unless EV output of measurement value (PV) is used at high alarm.
- *7 Not indicated unless EV output of measurement value (PV) is used at low alarm.
- *8 Not indicated unless EV output of measurement value (PV) is used at abnormal PV/heater function.
- *9 Not indicated unless CT input is type-specified or heater abnormal function is used.
- *10 Not indicated unless CT input is type-specified.

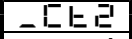
2.6 Event Output 2 (EV Output 2) Setting Mode



- PV  1.Selection display for setting mode
SV 
Press mode key
- PV  2.Setting for PV EV output 2 *11
SV 
Press mode key
- PV  3.High limit setting for EV output 2 *11*12*13
SV 
Press mode key
- PV  4.Low limit setting for EV output 2 *11*12*14
SV 
Press mode key
- PV  5.Sensitivity setting for EV 2 *11*12
SV 
Press mode key
- PV  6.Delay timer setting for EV 2 *11*12
SV 
Press mode key
- PV  7.Setting for abnormal PV/heater function in event output 2 *11
SV 
Press mode key
- PV  8.Polarity setting for EV output 2 *11
SV 
Press mode key
- PV  9.CT input Monitor *10
SV 
Press mode key
- PV  10.Abnormal current setting for EV output 2 *11*16
SV 
Press mode key
- Return to 1

Notes



- *11 Not indicated unless EV 2 is type-specified.
- *12 Not indicated unless EV 2 is type-specified or EV output of measurement value (PV) is used.
- *13 Not indicated unless EV 2 is type-specified or EV output of measurement value (PV) is used at high alarm.
- *14 Not indicated unless EV 2 is type-specified or EV output of measurement value (PV) is used at low alarm.
- *15 Not indicated unless EV 2 is type-specified or EV output of measurement value (PV) is used abnormal PV/heater function.
- *16 Not indicated unless EV 2 and CT input are type specified or heater abnormal function is used.

	図番 DWG.	PAGE 10/21
--	---------	---------------

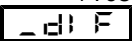

2.7 DI Setting Mode(DI:Digital Input)

PV  1.Selection display for setting mode
SV 



Press mode key

PV  2.Setting for DI input *15
SV 

Press mode key

PV  3.Setting for DI polarity *15
SV 

Press mode key

PV  4.Setting for control 2 *15*16
SV 

Press mode key

Return to 1

Notes

*15 Not indicated unless DI is type-specified.

*16 Not indicated unless SV selectable function is used.

2.8 Communication Setting Mode

- PV 1.Selection display for setting mode
SV
- Press mode key
- PV 2.Setting for communication parameter *17
SV
- Press mode key
- PV 3.Setting for communication speed *17
SV
- Press mode key
- PV 4.Setting for communication address *17
SV
- Press mode key
- PV 5.Setting for response delay time *17
SV
- Press mode key
- PV 6.Setting for communication selectable mode *17
SV
- Press mode key
Return to 1

Note

*17 Not indicated unless communication function is type-specified.

2.9 Timer Setting Mode

- PV 1.Setting mode for selection display
SV
- Press mode key
- PV 2.Setting for timer output
SV
- Press mode key
- PV 3.Setting for timer function *18
SV
- Press mode key
- PV 4.Change of timer unit *18
SV
- Press mode key
- PV 5.Setting for allowable width of timer SV start *18 *19
SV
- Press mode key
- PV 6.Time Setting *18
SV
- Press mode key
- PV 7.Monitor setting for remaining time *18
SV
- Press mode key
Return to 1

Notes

*18 Not indicated unless timer function is selected.

*19 Not indicated unless SV start is selected.

	図番 DWG.	PAGE 12/21
--	---------	---------------

3. Parameter Information

3.1 Operation Mode

	Character	Name	Description	Initial value
		Operation mode	usual mode for PV/SV	
1		Setting of control	Setting range : SLL ~ SLH Setting unit :	<input type="checkbox"/>
2		Priority display 1to9	Indication apperred, being set at priority display	/
3				
4				
5				
6				
7				
8				
9				
10				

3.2 Priority Display Setting Mode

	Character	Name	Description	Initial value
1	SEt <input type="checkbox"/>	Selection display on setting mode	Setting for priority display	
2	P-1 1	Priority display 1 to 9	Setting for parameter to be indicated on priority display.	display 1to9 OFF
3	P-1 2			
4	P-1 3			
5	P-1 4			
6	P-1 5			
7	P-1 6			
8	P-1 7			
9	P-1 8			
10	P-1 9			

	図番 DWG.	PAGE 13/21
--	---------	---------------

3.3 Set-Up Mode

Character	Name	Description	Initial value																									
1	SEI I	Selection display on setting mode	Setting related with input																									
2	_I n P	Setting for input types	<table border="1" style="margin-left: 20px;"> <tr> <td colspan="2">_I n P</td> </tr> <tr> <td colspan="2">Thermocouple/R.T.D</td> </tr> <tr> <td></td> <td>Input type</td> </tr> <tr> <td>00</td> <td>K Thermocouple</td> </tr> <tr> <td>01</td> <td>J Thermocouple</td> </tr> <tr> <td>02</td> <td>R Thermocouple</td> </tr> <tr> <td>03</td> <td>T Thermocouple</td> </tr> <tr> <td>04</td> <td>N Thermocouple</td> </tr> <tr> <td>05</td> <td>S Thermocouple</td> </tr> <tr> <td>06</td> <td>B Thermocouple</td> </tr> <tr> <td>10</td> <td>P t 1 0 0</td> </tr> <tr> <td>11</td> <td>J P t 1 0 0</td> </tr> </table>	_I n P		Thermocouple/R.T.D			Input type	00	K Thermocouple	01	J Thermocouple	02	R Thermocouple	03	T Thermocouple	04	N Thermocouple	05	S Thermocouple	06	B Thermocouple	10	P t 1 0 0	11	J P t 1 0 0	00
_I n P																												
Thermocouple/R.T.D																												
	Input type																											
00	K Thermocouple																											
01	J Thermocouple																											
02	R Thermocouple																											
03	T Thermocouple																											
04	N Thermocouple																											
05	S Thermocouple																											
06	B Thermocouple																											
10	P t 1 0 0																											
11	J P t 1 0 0																											
3	_P u C	Gain setting for PV correction	Setting range : 0.50~2.00 Setting unit : doubling	1.00																								
4	_P u S	Zero point setting for PV correction	Setting range : -199~999 or -199.9~999.9 Setting unit :	0																								
5	_P d F	Setting for filter input	Setting range : 0~99sec.	1																								
6	_ d P	Setting for decimal position	<table border="1" style="margin-left: 20px;"> <tr> <td>0</td> <td>none</td> </tr> <tr> <td>0.0</td> <td>on decimal position</td> </tr> </table>	0	none	0.0	on decimal position	0																				
0	none																											
0.0	on decimal position																											
7	_ F U	Setting function by FUNC Key	<table border="1" style="margin-left: 20px;"> <tr> <td>0</td> <td>none</td> </tr> <tr> <td>1</td> <td>Change of digit</td> </tr> <tr> <td>2</td> <td>RUN/READY</td> </tr> <tr> <td>3</td> <td>AT</td> </tr> <tr> <td>4</td> <td>Timer start/Reset</td> </tr> </table>	0	none	1	Change of digit	2	RUN/READY	3	AT	4	Timer start/Reset	0														
0	none																											
1	Change of digit																											
2	RUN/READY																											
3	AT																											
4	Timer start/Reset																											
8	_L o C	Lock setting	<table border="1" style="margin-left: 20px;"> <tr> <td>0</td> <td>OFF</td> </tr> <tr> <td>1</td> <td>All lock</td> </tr> <tr> <td>2</td> <td>lock of operation mode only</td> </tr> <tr> <td>3</td> <td>lock except operation mode</td> </tr> </table>	0	OFF	1	All lock	2	lock of operation mode only	3	lock except operation mode	0																
0	OFF																											
1	All lock																											
2	lock of operation mode only																											
3	lock except operation mode																											

	図番 DWG.	PAGE 14/21
--	---------	---------------

3.4 Control Setting Mode

Character	Name	Description	Initial value
1	SEE 2	Selection display on setting mode	
2	_SLH	Setting for SV high limiter	1200
3	_SLL	Setting for SV low limiter	0
4	_Md	Control mode	rUn
5	_CnE	Setting of control type	When EV2 is not type-specified, 110 When EV2 is type-specified, 113
6	_dir	Setting for change of normal or reverse	0
7	_Mv1	Manipulated value for output 1	0.0
8	_EUn	Setting for tuning type	2

_CnE
*

Function	
	Type
0	Type A
1	Type B (Overshoot protection)

control type of output 1	
	Type
1	PID control
2	ON/OFF control

control type of Output 2	
*	Type
0	None
1	PID
2	ON/OFF
3	EV output

0	Reverse
1	Normal

1	Auto tuning : output 1
2	Self tuning : output 1
3	Auto tuning : output 2
4	Self tuning : output 2
5	Auto tuning : output 1/2

Auto tuning : choose above 1, 3 or 5 and press FUNC key once.
Call off Auto-tuning : Repress FUNC Key during auto-tuning operation.

	図番 DWG.	PAGE 15/21
--	---------	---------------

	Character	Name	Description	Initial value
9	_AEC	AT Coefficient	Setting range : 0. 1 to 10. 0 Setting unit : Multiple of proportional band (PB value x)	1.0
10	_AEC	AT sensitivity	Setting range : 0 to 999 or 0. 0 to 999. 9 Setting unit :	2.0
11	_PI	Output 1, proportional band setting	Setting range : 0.1 to 200. 0% Setting unit : % for SLL ~ SLH	3.0
12	_I	Integral time	Setting range : 0 to 3600 sec.	0
13	_D	Derivative time	Setting range : 0 to 3600 sec.	0
14	_EC	Output 1, proportional cycle setting	Setting range : 1 to 120 sec.	2.0
15	_ARB	Anti reset wind-up	Setting range : 0. 0 to 100.0% Setting unit : %	100.0
16	_NH1	manipulated value high limiter setting	Setting range : manipulated value Low limiter to 100. 0%	100.0
17	_NL1	manipulated value low limiter setting	Setting range : 0. 0% to manipulated value high limiter	0.0
18	_CI	Output 1, control sensitivity	Setting range : 0 to 999 or 0. 0 to 999. 9 Setting unit :	0
19	_CPI	Output 1, OFF position	Setting range : -199 to 999 or -1999. 9 to 999. 9 Setting unit :	0
20	_MV2	Output 2, manipulated value	Setting for manipulated value monitor output 2 and manipulated value setting on manual control. Display range : 0. 0 to 100. 0% Setting range : manipulated value Low to high limiter.	0.0
21	_P2	Output 2, proportional band	Setting range : 0.10 to 10. 00 Setting unit : Magnification to output 1 proportional band.	1.00
22	_E2	Output 2, proportional cycle	Setting range : 1 to 120 sec.	2.0
23	_NH2	Output 2, high limiter setting of manipulated value	Setting range : Low limiter of manipulated value to 100. 0%	100.0
24	_NL2	Output 2, low limiter setting of manipulated value	Setting range : 0. 0% to high limiter of manipulated value	0.0

	図番 DWG.	PAGE 16/21
--	---------	---------------

	Character	Name	Description	Initial value
25	_C2	Output 2, control sensitivity setting	Setting range : 0 to 999 or 0. 0 to 999.9 Setting unit :	□
26	_CP2	Output 2, OFF position setting	Setting range : -199 to 999 or -199. 9 to 999. 9 Setting unit :	□
27	_Pbb	Manual reset	Setting range : 0. 0 to 100. 0% -100.0 to 100.0 (Heating/Cooling) Setting unit : %	□□
28	_db	Dead band setting	Setting range : -100.0 to 100.0 -100 to 100 Setting unit :	□

	図番 DWG.	PAGE 17/21
--	---------	---------------

3.5 Setting Mode of Event Output (Ev Output 1 & 2)

	Character	Name	Description	Initial value																																				
1	SEE 3 4	Selection display of setting mode EV output 1 EV output 2	Setting related with EV output 1 and EV output 2																																					
2	_EF	EV setting/function (PV & Additional event)	<table border="1"> <tr> <td colspan="2">_EF</td> </tr> <tr> <td colspan="2">PV EV function</td> </tr> <tr> <td></td> <td>Type</td> </tr> <tr> <td>0</td> <td>None</td> </tr> <tr> <td>1</td> <td>Deviation high and low limit</td> </tr> <tr> <td>2</td> <td>Deviation high limit</td> </tr> <tr> <td>3</td> <td>Deviation low limit</td> </tr> <tr> <td>4</td> <td>Deviation high and low limit range</td> </tr> <tr> <td>5</td> <td>High and low limit</td> </tr> <tr> <td>6</td> <td>High limit</td> </tr> <tr> <td>7</td> <td>Low limit</td> </tr> <tr> <td>8</td> <td>High and low limit range</td> </tr> <tr> <td colspan="2">Additional EV function</td> </tr> <tr> <td></td> <td>Type</td> </tr> <tr> <td>0</td> <td>None</td> </tr> <tr> <td>1</td> <td>EV Output hold</td> </tr> <tr> <td>2</td> <td>Stand-by sequence</td> </tr> <tr> <td>3</td> <td>EV output hold & stand-by sequence</td> </tr> </table>	_EF		PV EV function			Type	0	None	1	Deviation high and low limit	2	Deviation high limit	3	Deviation low limit	4	Deviation high and low limit range	5	High and low limit	6	High limit	7	Low limit	8	High and low limit range	Additional EV function			Type	0	None	1	EV Output hold	2	Stand-by sequence	3	EV output hold & stand-by sequence	00
_EF																																								
PV EV function																																								
	Type																																							
0	None																																							
1	Deviation high and low limit																																							
2	Deviation high limit																																							
3	Deviation low limit																																							
4	Deviation high and low limit range																																							
5	High and low limit																																							
6	High limit																																							
7	Low limit																																							
8	High and low limit range																																							
Additional EV function																																								
	Type																																							
0	None																																							
1	EV Output hold																																							
2	Stand-by sequence																																							
3	EV output hold & stand-by sequence																																							
3	_EH	High limit setting	Range : -199. 9 to 999. 9	0																																				
4	_EL	Low limit setting	Unit : -1999 ~ 9999																																					
5	_EC	Setting of EV output sensitivity	Range : 0. 0 to 999. 9 , 0 to 9999 Unit :	0																																				
6	_EE	Delay timer setting	Range : 0 to 9999 sec.	0																																				
7	_Eb	Abnormal SV/heater function setting	<table border="1"> <tr> <td colspan="2">_Eb</td> </tr> <tr> <td></td> <td>Type</td> </tr> <tr> <td>0</td> <td>None</td> </tr> <tr> <td>1</td> <td>PV EV output abnormal</td> </tr> <tr> <td>2</td> <td>Heater abnormal</td> </tr> <tr> <td>3</td> <td>PV EV output abnormal & heater abnormal</td> </tr> <tr> <td colspan="2">Additional EV function</td> </tr> <tr> <td></td> <td>Type</td> </tr> <tr> <td>0</td> <td>None</td> </tr> <tr> <td>1</td> <td>EV output hold</td> </tr> </table>	_Eb			Type	0	None	1	PV EV output abnormal	2	Heater abnormal	3	PV EV output abnormal & heater abnormal	Additional EV function			Type	0	None	1	EV output hold	00																
_Eb																																								
	Type																																							
0	None																																							
1	PV EV output abnormal																																							
2	Heater abnormal																																							
3	PV EV output abnormal & heater abnormal																																							
Additional EV function																																								
	Type																																							
0	None																																							
1	EV output hold																																							
8	_EP	Polarity setting of EV output	<table border="1"> <tr> <td colspan="2">_EP</td> </tr> <tr> <td></td> <td>Type</td> </tr> <tr> <td>0</td> <td>Normal Open (NO)</td> </tr> <tr> <td>1</td> <td>Normal Close (NC)</td> </tr> </table>	_EP			Type	0	Normal Open (NO)	1	Normal Close (NC)	0																												
_EP																																								
	Type																																							
0	Normal Open (NO)																																							
1	Normal Close (NC)																																							
9	_CE	CT input monitor	Watching for current value of heater current detector Display range : 1 to 60A																																					
10	_CE	Setting of heater abnormal current	Range : 1 to 30A	1																																				

	図番 DWG.	PAGE 18/21
--	---------	---------------

3.6 Setting Mode of DI

Character	Name	Description	Initial value																											
1	SEES	Selection display of setting mode																												
2	_d:F	Contents of DI function	1																											
		<table border="1"> <tr> <td colspan="3" style="text-align: center;">_d:F</td> </tr> <tr> <td></td> <td></td> <td>Active</td> </tr> <tr> <td>1</td> <td>SV</td> <td>SV2</td> </tr> <tr> <td>2</td> <td>RUN</td> <td>READY</td> </tr> <tr> <td>3</td> <td>RUN</td> <td>Manual</td> </tr> <tr> <td>4</td> <td>Reverse</td> <td>Normal</td> </tr> <tr> <td>5</td> <td></td> <td>AT start</td> </tr> <tr> <td>6</td> <td>Reverse sv</td> <td>Normal SV2</td> </tr> <tr> <td>7</td> <td></td> <td>Timer start and reset</td> </tr> </table>	_d:F					Active	1	SV	SV2	2	RUN	READY	3	RUN	Manual	4	Reverse	Normal	5		AT start	6	Reverse sv	Normal SV2	7		Timer start and reset	
_d:F																														
		Active																												
1	SV	SV2																												
2	RUN	READY																												
3	RUN	Manual																												
4	Reverse	Normal																												
5		AT start																												
6	Reverse sv	Normal SV2																												
7		Timer start and reset																												
3	_d:P	Polarity setting of DI	0																											
		<table border="1"> <tr> <td colspan="2" style="text-align: center;">_d:P</td> </tr> <tr> <td></td> <td>Polarity</td> </tr> <tr> <td>0</td> <td>close active</td> </tr> <tr> <td>1</td> <td>open active</td> </tr> </table>	_d:P			Polarity	0	close active	1	open active																				
_d:P																														
	Polarity																													
0	close active																													
1	open active																													
4	_Sv2	Control setting 2	0																											
		Range : SLL ~ SLH Unit :																												

	図番 DWG.	PAGE 19/21
--	---------	---------------

3.7 Communication Mode Setting

Character	Name	Description	Initial value																												
1	SELE	Selection display of setting mode																													
2	_CoN	Communication parameter setting	68n2																												
		<table border="1"> <tr> <td>_CoN</td> <td>*</td> </tr> </table> <p>BCC check</p> <table border="1"> <tr> <td></td> <td>Type</td> </tr> <tr> <td>n</td> <td>None</td> </tr> <tr> <td>b</td> <td>Functional</td> </tr> </table> <p>Data length</p> <table border="1"> <tr> <td>*</td> <td>Type</td> </tr> <tr> <td>7</td> <td>7 bits</td> </tr> <tr> <td>8</td> <td>8 bits</td> </tr> </table> <p>Parity check</p> <table border="1"> <tr> <td></td> <td>Type</td> </tr> <tr> <td>n</td> <td>None</td> </tr> <tr> <td>o</td> <td>Odd number</td> </tr> <tr> <td>E</td> <td>Even number</td> </tr> </table> <p>Stop bit</p> <table border="1"> <tr> <td></td> <td>Type</td> </tr> <tr> <td>1</td> <td>1 bits</td> </tr> <tr> <td>2</td> <td>2 bits</td> </tr> </table>	_CoN	*		Type	n	None	b	Functional	*	Type	7	7 bits	8	8 bits		Type	n	None	o	Odd number	E	Even number		Type	1	1 bits	2	2 bits	
_CoN	*																														
	Type																														
n	None																														
b	Functional																														
*	Type																														
7	7 bits																														
8	8 bits																														
	Type																														
n	None																														
o	Odd number																														
E	Even number																														
	Type																														
1	1 bits																														
2	2 bits																														
3	_bPS	Communication speed setting	9.6																												
		<table border="1"> <tr> <td>1.2</td> <td>1 2 0 0 b p s</td> </tr> <tr> <td>2.4</td> <td>2 4 0 0 b p s</td> </tr> <tr> <td>4.8</td> <td>4 8 0 0 b p s</td> </tr> <tr> <td>9.6</td> <td>9 6 0 0 b p s</td> </tr> <tr> <td>19.2</td> <td>1 9 2 0 0 b p s</td> </tr> </table>	1.2	1 2 0 0 b p s	2.4	2 4 0 0 b p s	4.8	4 8 0 0 b p s	9.6	9 6 0 0 b p s	19.2	1 9 2 0 0 b p s																			
1.2	1 2 0 0 b p s																														
2.4	2 4 0 0 b p s																														
4.8	4 8 0 0 b p s																														
9.6	9 6 0 0 b p s																														
19.2	1 9 2 0 0 b p s																														
4	_Adr	Communication address	1																												
		Setting range : 1 to 99 stations																													
5	_ABE	Response delay time	0																												
		Setting range : 0 to 250ms																													
6	_Mod	Communication mode switch	nB																												
		<table border="1"> <tr> <td>ro</td> <td>Reading only</td> </tr> <tr> <td>rB</td> <td>Reading and writing available</td> </tr> </table>	ro	Reading only	rB	Reading and writing available																									
ro	Reading only																														
rB	Reading and writing available																														

	図番 DWG.	PAGE 20/21
--	---------	---------------

3.8 Timer Mode Setting

Character	Name	Description	Initial value																
1	SE7	Selection display of setting mode	Setting concerned with timer parameters																
2	EN0	Timer output setting	<table border="1"> <thead> <tr> <th></th> <th>Output type</th> </tr> </thead> <tbody> <tr> <td>0</td> <td>Non-use timer function</td> </tr> <tr> <td>1</td> <td>Control</td> </tr> <tr> <td>2</td> <td>EV output 1</td> </tr> </tbody> </table>		Output type	0	Non-use timer function	1	Control	2	EV output 1								
	Output type																		
0	Non-use timer function																		
1	Control																		
2	EV output 1																		
3	ENF	Timer function setting	<table border="1"> <thead> <tr> <th></th> <th>type</th> </tr> </thead> <tbody> <tr> <td>1</td> <td>Auto-start (on delay)</td> </tr> <tr> <td>2</td> <td>Manual start (on delay)</td> </tr> <tr> <td>3</td> <td>EV start (on delay)</td> </tr> <tr> <td>4</td> <td>Auto-start (off delay)</td> </tr> <tr> <td>5</td> <td>Manual start (off delay)</td> </tr> <tr> <td>6</td> <td>EV start (off delay)</td> </tr> <tr> <td>7</td> <td>SV start (off delay)</td> </tr> </tbody> </table>		type	1	Auto-start (on delay)	2	Manual start (on delay)	3	EV start (on delay)	4	Auto-start (off delay)	5	Manual start (off delay)	6	EV start (off delay)	7	SV start (off delay)
	type																		
1	Auto-start (on delay)																		
2	Manual start (on delay)																		
3	EV start (on delay)																		
4	Auto-start (off delay)																		
5	Manual start (off delay)																		
6	EV start (off delay)																		
7	SV start (off delay)																		
4	HFN	Timer unit switch	<table border="1"> <tbody> <tr> <td>1</td> <td>Hour, Minute</td> </tr> <tr> <td>2</td> <td>Minute, Second</td> </tr> </tbody> </table>	1	Hour, Minute	2	Minute, Second												
1	Hour, Minute																		
2	Minute, Second																		
5	ES0	Setting of allowable width for timer SV START	Range : -199 to 999 or -199. 9 to 999. 9 Unit :																
6	ETN	Time setting	Range : 0:00 to 99:59 (hour, minute) 0:00 to 59:59 (minute, second)																
7	ETA	Monitor setting of remaining time	Monitor of remaining time Press FUNC key one time at this display, then timer starts.																

	図番 DWG.	PAGE 21/21
--	---------	---------------

4 . Shifts to Blind Setting Mode

Power ON

After power ON, it shows " Type of input display" for 4 seconds. Then, the display automatically changes into operation mode.

Initial display for 4 seconds

Operation mode

Hold down mode key for 10 seconds. Then, the display blinks. Press FUNC Key at once. Press MODE Key at once.

Blind setting mode

Reset the power for blind setting mode OFF.

5 . Other Display Indication



Displays whenever input value exceeds the high limit of display range. Also displays when the wire is snapped off thermocouple, ABb terminal off R.T.D.

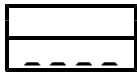

Displays whenever input value exceeds the low limit of display range.

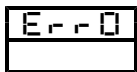

Displays at memory error.



Displays at A/D converter error.

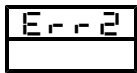

Displays at auto-tuning error.

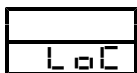

Displays when the operator tries to change parameter in key lock.



Displays this and normal screen by turns, during auto-tuning.

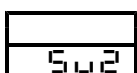

Displays when the operator tries to change setting value during control at SV2.

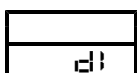

Displays when the operator tries to change setting value of the shift at D1.

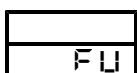

Displays when the operator tries to change setting value in control display.